

2

1

MATERIAL:
GRAY CAST IRON TO ASTM A48
CLASS 30B

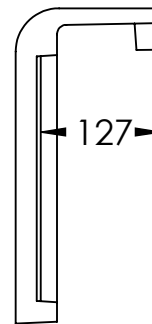
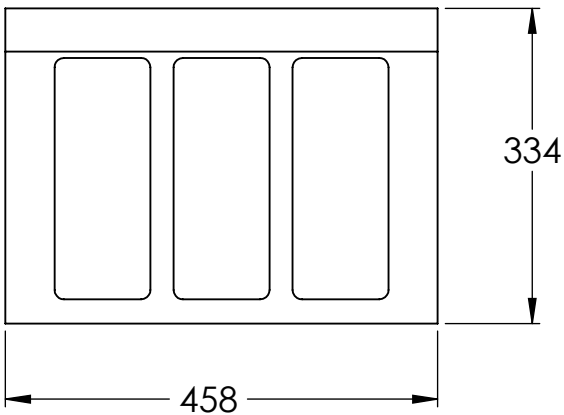
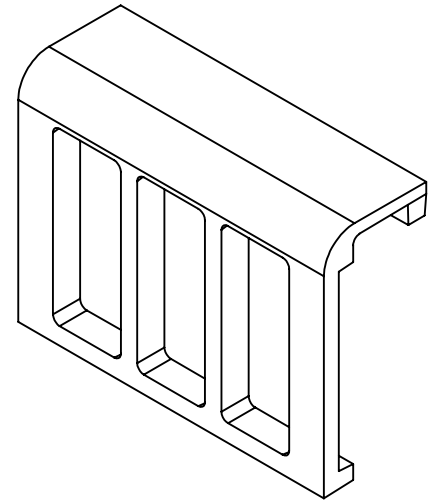
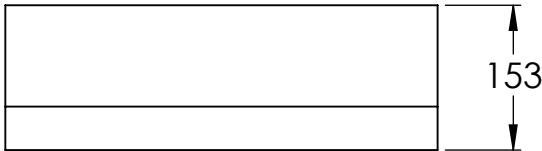

NOTES:

- 1) CONFORMS TO CITY OF WINNIPEG
- 2) WEIGHT 24.5 KGS. (54 LBS.)
- 3) ALL DIMENSIONS ARE IN mm

KAROH

**KRMH.110.CG.03 3 HOLE CURB
GRATE**

IDEAL SPECIFIED PRODUCTS

45 SYLVAN WAY.
WINNIPEG (MB) R2R 2B9
CANADA

DESIGNED BY: AG

DESIGN DATE: DEC 6, 2019

REFERENCE DRAWING:

DRAWN BY: AG

REV. DATE: DEC 31 / 2020

CITY OF WINNIPEG WATER AND
WASTE WASTE DEPT

CHECKED BY: WF

REV. NO: 1

DO NOT SCALE DRAWING

2

1

B

B

A

A