

2

1

MATERIAL:
GRAY CAST IRON TO ASTM A48
CLASS 30B

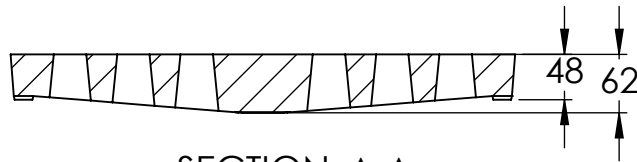
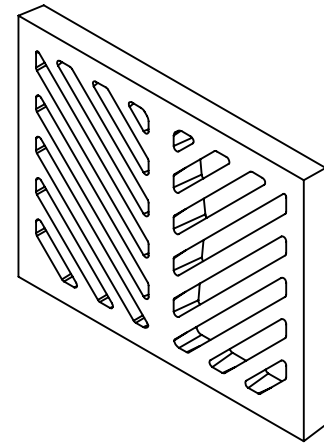
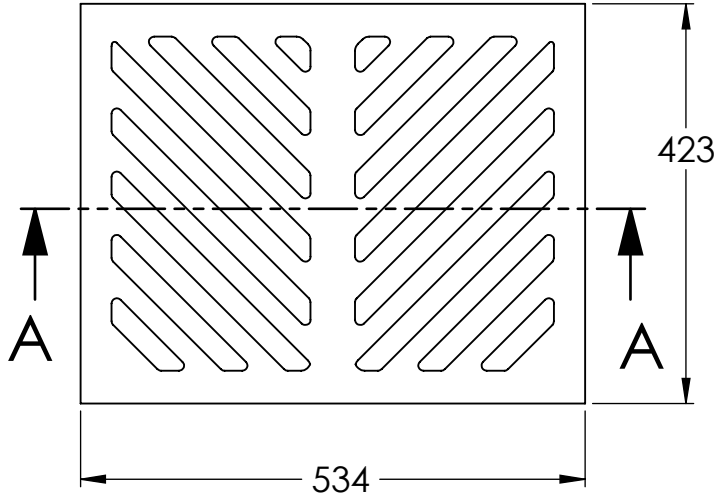

SECTION A-A

NOTES:

- 1) CONFORMS TO CITY OF WINNIPEG AP-014
- 2) WEIGHT 46.7 KGS. (103 LBS.)
- 3) ALL DIMENSIONS ARE IN mm

KAROH

**KRMH.014.BCRG BARRIER CURB RISER
GRATE**

IDEAL SPECIFIED PRODUCTS

45 SYLVAN WAY.
WINNIPEG (MB) R2R 2B9
CANADA

DESIGNED BY: AG

DESIGN DATE: DEC 6, 2019

REFERENCE DRAWING:

DRAWN BY: AG

REV. DATE: DEC 31 / 2021

CITY OF WINNIPEG WATER AND
WASTE WASTE DEPT
DRAWING NO: AP-014

CHECKED BY: WF

REV. NO: 1

DO NOT SCALE DRAWING

2

1