

2

1

MATERIAL:  
GRAY CAST IRON TO ASTM A48  
CLASS 30B

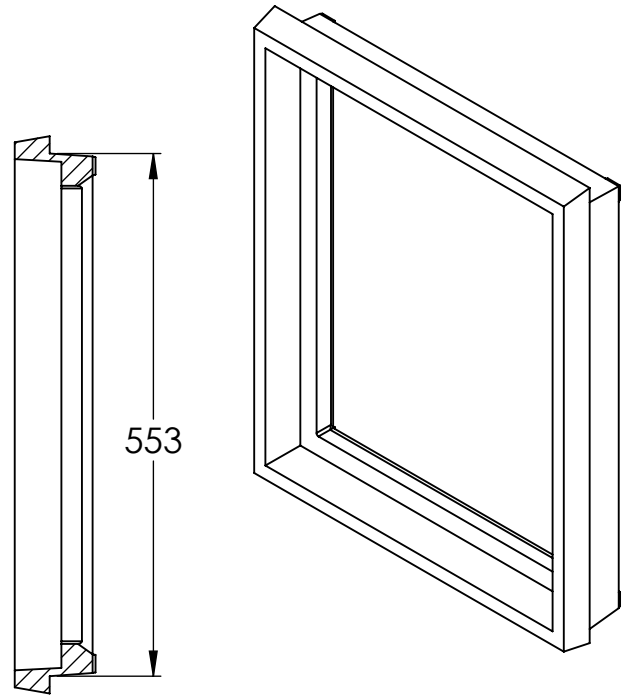
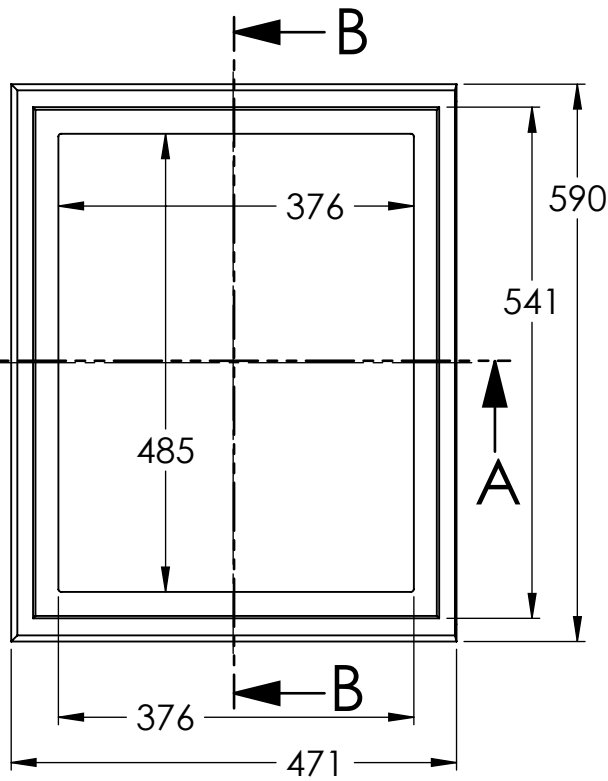

SECTION B-B

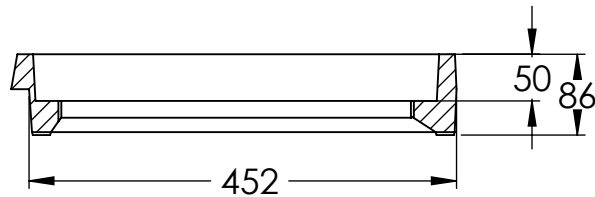

SECTION A-A

NOTES:

- 1) CONFORMS TO CITY OF WINNIPEG AP-013
- 2) WEIGHT 27.12 KGS. ( 60 LBS.)
- 3) ALL DIMENSIONS ARE IN mm

**KAROH**

**KRMH.013.BCRF.15 BARRIER CURB RISER  
FRAME (38mm)(1-1/2")**

**IDEAL SPECIFIED PRODUCTS**

45 SYLVAN WAY.  
WINNIPEG (MB) R2R 2B9  
CANADA

DESIGNED BY: AG

DESIGN DATE: DEC 6, 2019

REFERENCE DRAWING:

DRAWN BY: AG

REV. DATE: DEC 31 / 2020

CITY OF WINNIPEG WATER AND  
WASTE WASTE DEPT  
DRAWING NO: AP-013

CHECKED BY: WF

REV. NO: 1

DO NOT SCALE DRAWING

2

1

B

B

A

A