

MATERIAL:
1. DUCTILE IRON ASTM A536 GR. 65-45-12

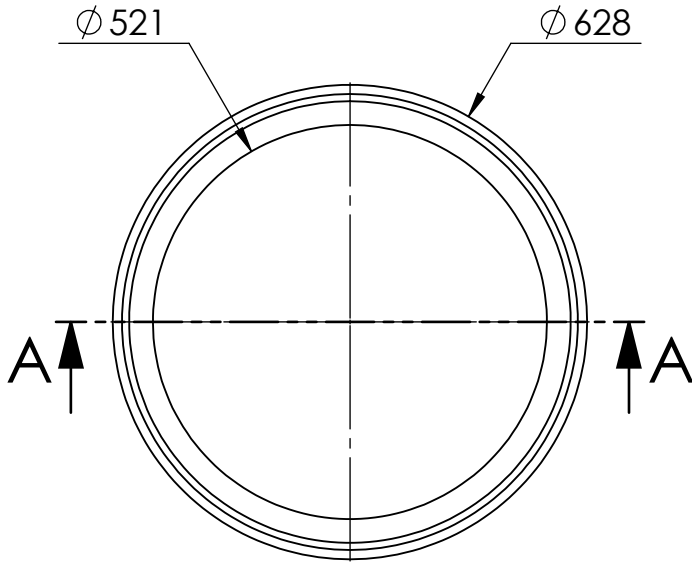

DETAILS

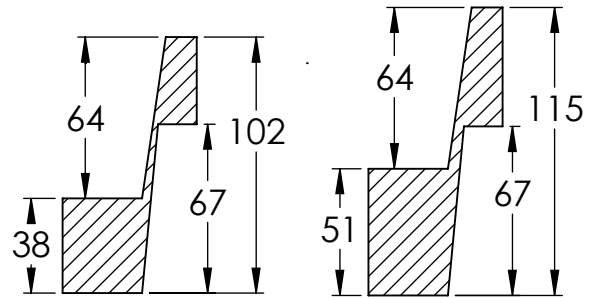

38mm (1.5") LIFT
KR010-1.5

50mm (2") LIFT
KR010-2

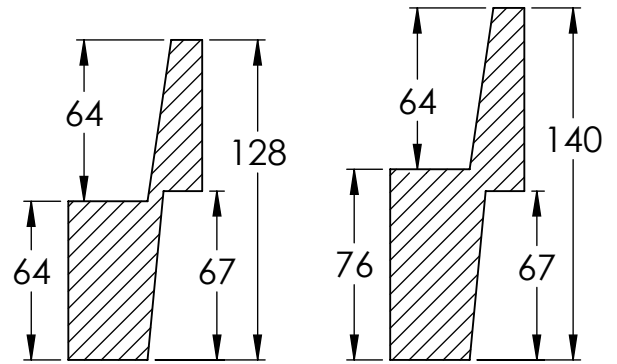

63.5mm (2.5") LIFT
KR010-2.5

38mm (3") LIFT
KR010-3

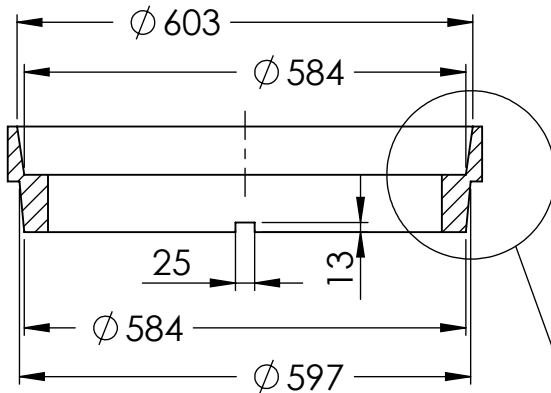

SECTION A-A

SEE DETAILS

KRMH.010.MRR.15	(38mm) (1-1/2")
KRMH.010.MRR.02	(50mm) (2")
KRMH.010.MRR.25	(63.5mm) (2-1/2")
KRMH.010.MRR.03	(75mm) (3")

NOTES:

- CONFORMS TO CITY OF WINNIPEG STANDARD DRAWING SD 107A
- FOR USE WITH WD50F ,TITAN TF-101, OR KR MANHOLE FRAMES

KAROH

ROUND MANHOLE LIFTER RINGS

IDEAL SPECIFIED PRODUCTS

45 SYLVAN WAY
WINNIPEG (MB) R2R 2B9
CANADA

DESIGNED BY: AG

DESIGN DATE: DEC 6, 2019

REFERENCE DRAWING:

DRAWN BY: AG

REV. DATE: DEC 31 / 2021

CITY OF WINNIPEG WATER AND
WASTE WASTE DEPT
DRAWING NO: AP-010

CHECKED BY: WF

REV. NO: 1

DO NOT SCALE DRAWING