

2

1

MATERIAL:
GRAY CAST IRON TO ASTM A48
CLASS 30B

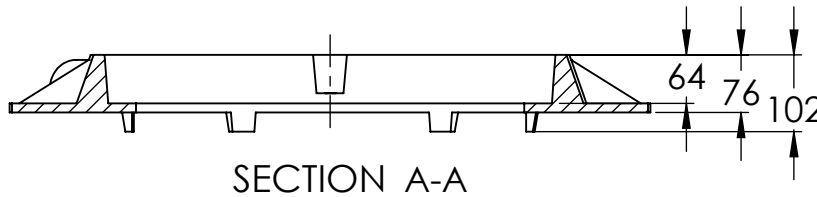
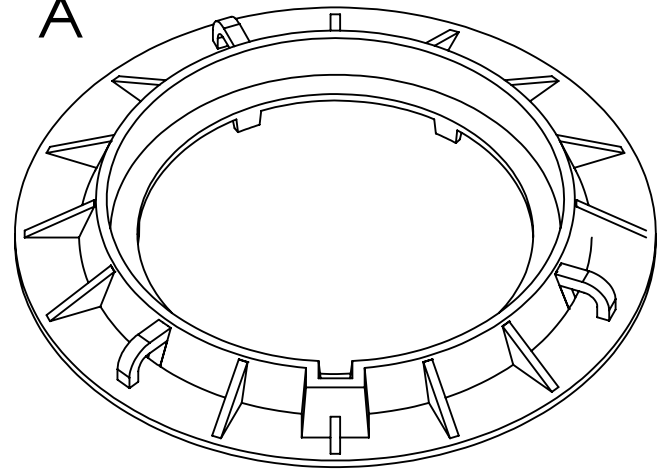
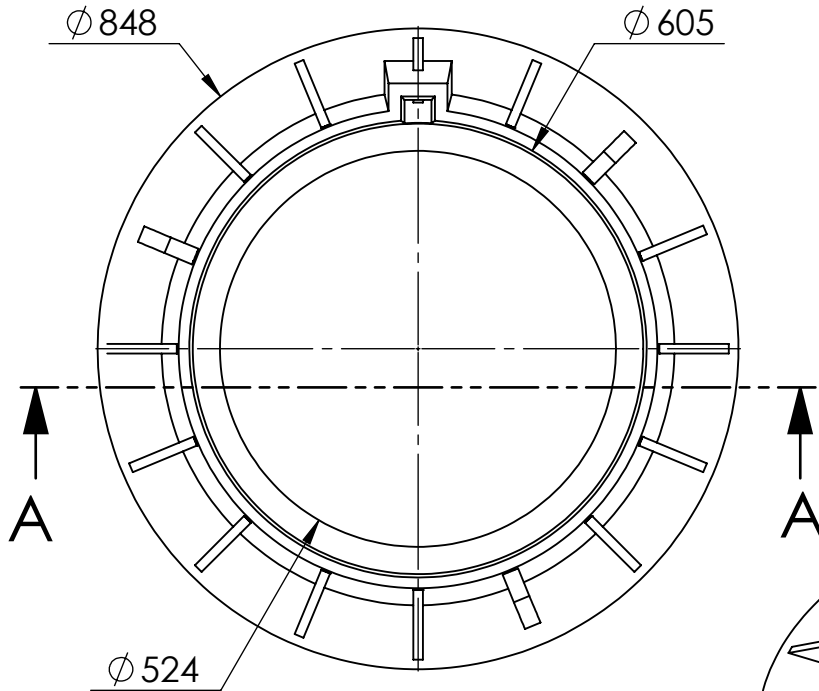

- NOTES:
 1) CONFORMS TO CITY OF WINNIPEG AP-006
 2) WEIGHT 60.2 KGS. (133 LBS.)
 3) ALL DIMENSIONS IN mm

KAROH

KRMH.006.MHF.R.03 ROUND MANHOLE 3" FRAME

IDEAL SPECIFIED PRODUCTS

45 SYLVAN WAY.
WINNIPEG (MB) R2R 2B9
CANADA

DESIGNED BY: AG

DESIGN DATE: DEC 6, 2019

REFERENCE DRAWING:

DRAWN BY: AG

REV. DATE: DEC 31 / 2020

CITY OF WINNIPEG WATER AND
WASTE WASTE DEPT
DRAWING NO: AP-006

CHECKED BY: WF

REV. NO: 1

DO NOT SCALE DRAWING

2

1