

2

1

MATERIAL:  
GRAY CAST IRON TO ASTM A48  
CLASS 30B

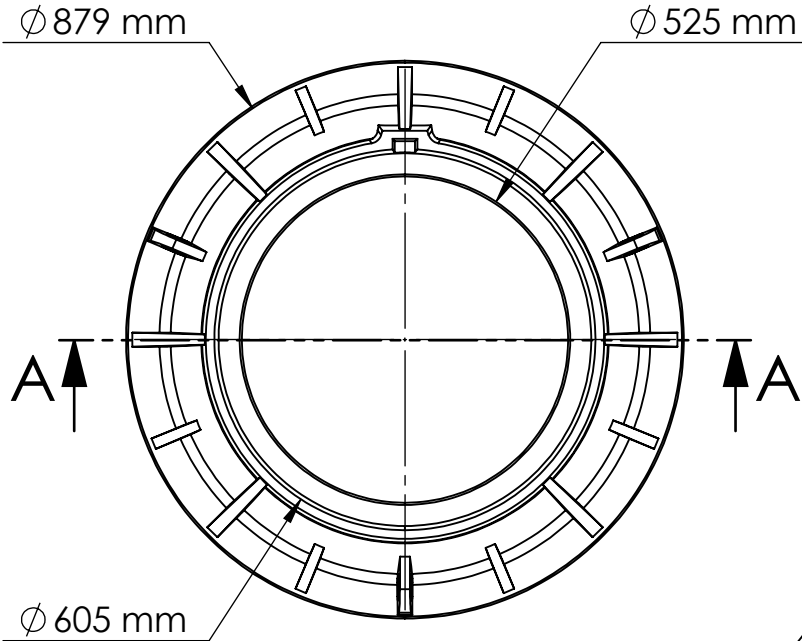

**TOP VIEW**

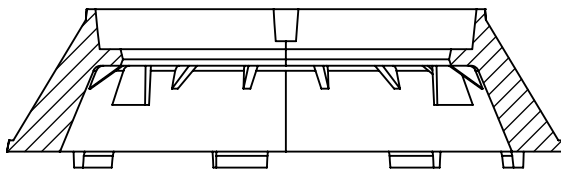
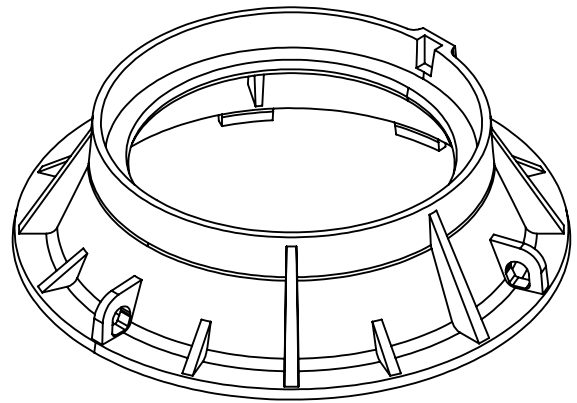

**SECTION A-A**

- NOTES:  
 1) CONFORMS TO CITY OF WINNIPEG AP-006  
 2) WEIGHT 103 KGS. (227 LBS.)

**KAROH**

**KRMH.006.MHF.R.10 ROUND MANHOLE 10" FRAME**

**IDEAL SPECIFIED PRODUCTS**

45 SYLVAN WAY.  
WINNIPEG (MB) R2R 2B9  
CANADA

DESIGNED BY: AG

DESIGN DATE: DEC 6, 2019

REFERENCE DRAWING:

DRAWN BY: AG

REV. DATE: DEC 31/2021

CITY OF WINNIPEG WATER AND  
WASTE WASTE DEPT  
DRAWING NO: AP-006

CHECKED BY: WF

REV. NO: 1

DO NOT SCALE DRAWING

2

1