

2

1

ITEM NO.	PART NUMBER	DESCRIPTION	QTY.
1	GS.06.61.1.RP	STONE CATCHER BODY	1
2	BT.38.23.SUB.Z4	2" X 3" SQ. "U" BOLT ZINC PLATED	1

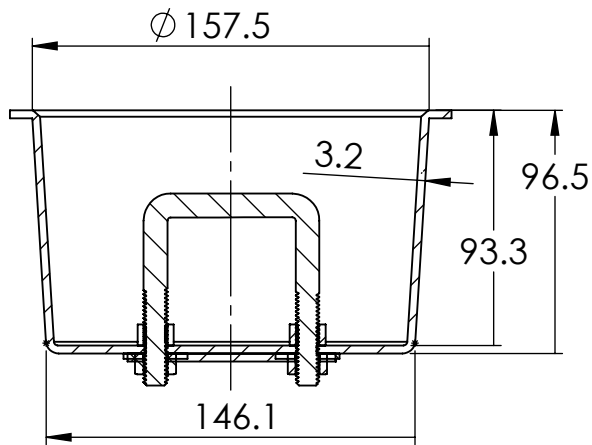
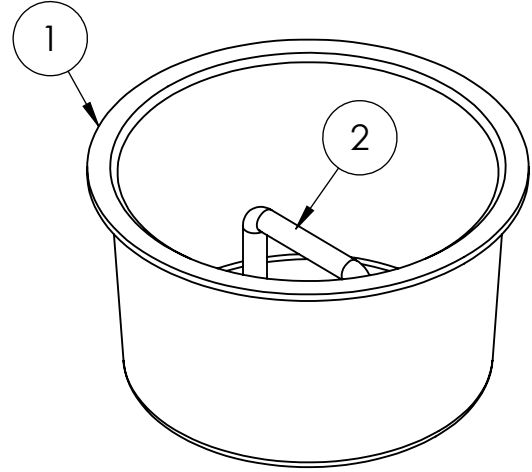
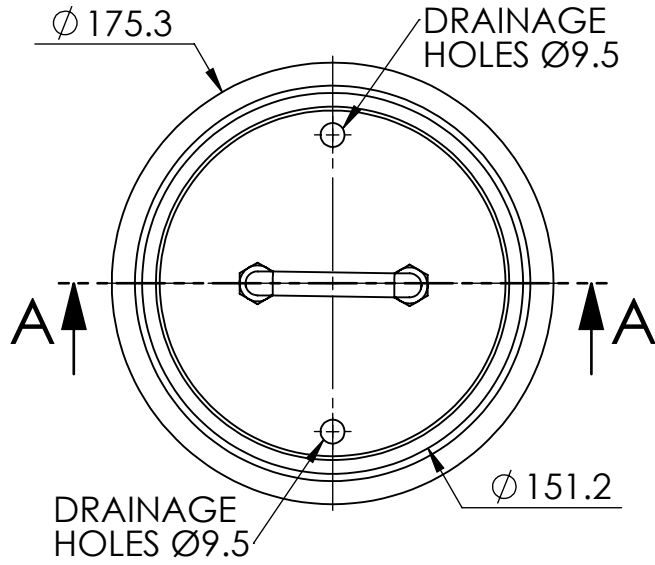

SECTION A-A

SCALE 1 : 3

NOTES:
 ITEM #1 MATERIAL HDPE PLASTIC BLACK
 ALL DIMENSIONS IN mm

KAROH

**KR 001.VB.SC STONE CATCHER FOR
 KR001/KR001C VALVE BOXES**

IDEAL SPECIFIED PRODUCTS

45 SYLVAN WAY
 WINNIPEG (MB) R2R 2B9
 CANADA

DESIGNED BY: AG

DESIGN DATE: DEC 09/2019

REFERENCE DRAWING:

DRAWN BY: AG

REV. DATE: DEC 31 / 2020

CITY OF WINNIPEG WATER AND
 WASTE WASTE DEPT
 DRAWING NO:

CHECKED BY: WF

REV. NO: 1

DO NOT SCALE DRAWING

2

1

2

1

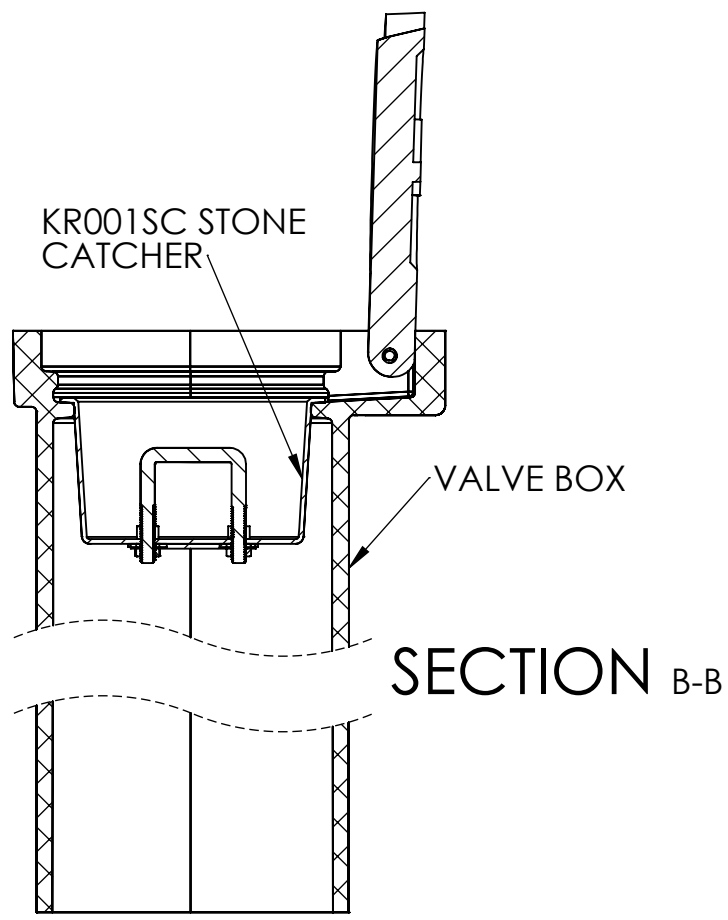
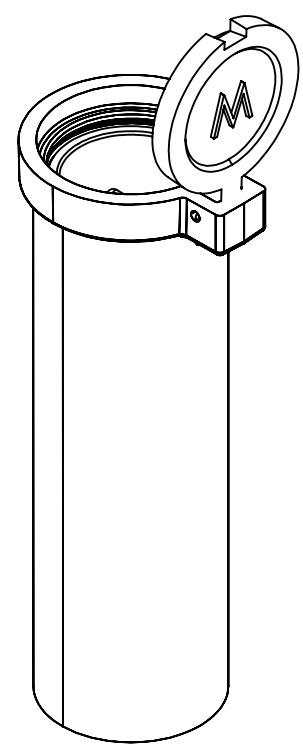
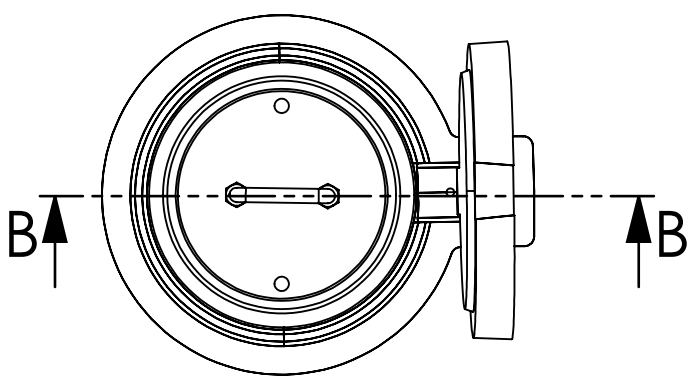

B

B

A

A

KAROH

KR001SC STONE CATCHER FIT

IDEAL SPECIFIED PRODUCTS

45 SYLVAN WAY
 WINNIPEG (MB) R2R 2B9
 CANADA

DESIGNED BY: AG	DESIGN DATE: DEC 09/20
DRAWN BY: AG	REV. DATE: DEC 31/21
CHECKED BY: WF	REV. NO: 1
DO NOT SCALE DRAWING	

REFERENCE DRAWING:
 CITY OF WINNIPEG WATER AND
 WASTE WASTE DEPT
 DRAWING NO:

2

1